

## Manitowoc Crane Group

WIRE NO	COLOR	SAE SIZE	LENGTH TOT IN	TP	B/M ITEM NO	REMARKS	TP	B/M ITEM NO	REMARKS
SHLD8	WHT GXL	16	4	BG	STRIP	SEE CABLE PC1C	BG	STRIP	SEE CABLE PC1C
SHLD9		16	4	AM	STRIP	SEE CABLE PC2B	AM	STRIP	SEE CABLE PC2B
SHLD10		16	4	BG	STRIP	SEE CABLE PC2C	BG	STRIP	SEE CABLE PC2C
SHLD11		16	4	BE	STRIP	SEE CABLE RB	BE	STRIP	SEE CABLE RB
AE7		16	6	AE	49	---	---	SEE NOTE 8	---
AM1		16	8	AM	48	---	---	SEE NOTE 8	---
AM4		16	8	AM	48	---	---	SEE NOTE 8	---
AM5		16	8	AM	48	---	---	SEE NOTE 8	---
BPA		16	8	BP	49	---	---	SEE NOTE 8	---
CD10		16	6	CD	49	---	---	SEE NOTE 8	---
CD11		16	6	CD	49	---	---	SEE NOTE 8	---
CD12		16	6	CD	49	---	---	SEE NOTE 8	---
CE1		12	8	CE	75	---	---	SEE NOTE 8	---
CE2		16	9	CE	48	---	---	SEE NOTE 8	---
CE3		16	9	CE	48	---	---	SEE NOTE 8	---
CE4		16	9	CE	48	---	---	SEE NOTE 8	---
CM1		16	7	CM	48	---	---	SEE NOTE 8	---
CN1		16	7	CN	48	---	---	SEE NOTE 8	---
CP6		16	8	CP	49	---	---	SEE NOTE 8	---
CP12	WHT GXL	16	8	CP	49	---	---	SEE NOTE 8	---

WIRE NUMBER LABELS FOR USE ON CABLE ASSYS									
WIRE NO	CONDUCTOR COLOR	SAE SIZE	LENGTH TOT IN	CABLE ASSY	TP	REMARKS	TP	REMARKS	LABLES REQ'D
1484A	RED	10	5	PC1A	BH	USE INSUL	SB6	USE INSUL	2
1484B	RED	10	5	PC1B	AM	USE INSUL	SB6	USE INSUL	2
1484C	RED	10	5	PC1C	BG	USE INSUL	SB6	USE INSUL	2
1485A	BLK	10	5	PC1A	BH	USE INSUL	SB6	USE INSUL	2
1485B	BLK	10	5	PC1B	AM	USE INSUL	SB6	USE INSUL	2
1485C	BLK	10	5	PC1C	BG	USE INSUL	SB6	USE INSUL	2
1486A	RED	10	5	PC2A	BH	USE INSUL	SB7	USE INSUL	2
1486B	RED	10	5	PC2B	AM	USE INSUL	SB7	USE INSUL	2
1486C	RED	10	5	PC2C	BG	USE INSUL	SB7	USE INSUL	2
1487A	BLK	10	5	PC2A	BH	USE INSUL	SB7	USE INSUL	2
1487B	BLK	10	5	PC2B	AM	USE INSUL	SB7	USE INSUL	2
1487C	BLK	10	5	PC2C	BG	USE INSUL	SB7	USE INSUL	2
1289A	RED	10	5	RA	BE	USE INSUL	CE	USE INSUL	2
1289B	RED	10	5	RB	BF	USE INSUL	SB2	USE INSUL	2
1289C	RED	10	5	RC	BE	USE INSUL	BD	USE INSUL	2
1289D	RED	10	5	RB	AM	USE INSUL	SB2	USE INSUL	2
1289E	RED	10	5	RB	BE	USE INSUL	SB2	USE INSUL	2
1290A	BLK	10	5	RA	BE	USE INSUL	CE	USE INSUL	2
1290B	BLK	10	5	RB	BF	USE INSUL	SB2	USE INSUL	2
1290C	BLK	10	5	RC	BE	USE INSUL	BD	USE INSUL	2
1290D	BLK	10	5	RB	AM	USE INSUL	SB2	USE INSUL	2
1290E	BLK	10	5	RB	BE	USE INSUL	SB2	USE INSUL	2
1323A	RED	10	5	RS	BF	USE INSUL	BD	USE INSUL	2
1324A	BLK	10	5	RS	BF	USE INSUL	BD	USE INSUL	2

# Manitowoc Crane Group

WIRE NO	COLOR	SAE SIZE	LENGTH TOT IN	TP	B/M ITEM NO	REMARKS	TP	B/M ITEM NO	REMARKS
134A	WHT GXL	16	152	BH	49	---	SA1	STRIP	SEE DETAIL
134B		16	21	AS	48	---	SA1	STRIP	SEE DETAIL
134C		16	74	AC	13,14	---	SA1	STRIP	SEE DETAIL
343		18	97	BH	45	---	CE	48	---
344A		12	5	SB1	STRIP	SEE DETAIL	BA	STRIP	NOTE 5
344B		12	63	SB1	STRIP	SEE DETAIL	SC7	STRIP	SEE DETAIL
344C		12	63	SB1	STRIP	SEE DETAIL	SC7	STRIP	SEE DETAIL
344D		12	8	CE	75	---	SC7	STRIP	SEE DETAIL
367		18	97	BH	49	---	CE	48	---
368		18	97	BH	49	---	CE	48	---
371		18	97	BH	49	---	CE	48	---
440A		18	25	BH	45	---	SB3	STRIP	SEE DETAIL
440B		18	95	AF	36,37	---	SB3	STRIP	SEE DETAIL
440C		18	102	CA	36,37	---	SB3	STRIP	SEE DETAIL
504		18	78	BH	49	---	BK	49	---
530		18	90	BP	49	---	BH	49	---
609A		18	87	BH	49	---	SC1	STRIP	SEE DETAIL
609B		18	10	CE	48	---	SC1	STRIP	SEE DETAIL
609C		18	96	CC	49	---	SC1	STRIP	SEE DETAIL
631		18	98	BH	49	---	BJ	49	---
713A		18	44	BH	45	---	SB5	STRIP	SEE DETAIL
713B		18	29	BL	49	---	SB5	STRIP	SEE DETAIL
713C		18	29	BL	49	---	SB5	STRIP	SEE DETAIL
787		18	78	BH	49	---	BK	49	---
792		18	105	BH	49	---	AL	49	---
793		18	105	BH	49	---	AL	49	---
842		18	130	BH	45	---	CB	51	---
1253	WHT GXL	16	33	BA	STRIP	NOTE 9	BD	48	---
1274	YEL SXL	6	56	AM	20	---	BC	25	---
1280	WHT GXL	16	81	CE	48	---	BM	45	---
1299		16	81	CE	48	---	BM	45	---
1358A		12	8	BA	STRIP	NOTE 5	BA	41	---
1358B		14	8	BA	STRIP	NOTE 5	BA	92	---
1358C		16	8	BA	STRIP	NOTE 9	BA	92	---
1410A		16	45	BH	49	---	SB5	STRIP	SEE DETAIL
1410B		18	117	AF	36,37	---	SB5	STRIP	SEE DETAIL
1410C		18	31	BK	49	---	SB5	STRIP	SEE DETAIL
1410D		18	85	CB	51	---	SB5	STRIP	SEE DETAIL
1410E		18	80	CA	36,37	---	SB5	STRIP	SEE DETAIL
1410F		18	75	BP	49	---	SB5	STRIP	SEE DETAIL
1414		8	59	BN	26	---	SB1	STRIP	SEE DETAIL
1463		14	62	BA	STRIP	NOTE 5	BG	15	---
1478		18	76	BH	45	---	BK	49	---
SHLD1		16	4	BE	STRIP	SEE CABLE RA	BE	STRIP	SEE CABLE RA
SHLD2		16	4	CE	STRIP	SEE CABLE RA	CE	STRIP	SEE CABLE RA
SHLD3		16	4	BE	STRIP	SEE CABLE RB	BE	STRIP	SEE CABLE RB
SHLD4		16	4	BF	STRIP	SEE CABLE RB	BF	STRIP	SEE CABLE RB
SHLD5		16	4	BE	STRIP	SEE CABLE RC	BE	STRIP	SEE CABLE RC
SHLD6		16	4	BD	STRIP	SEE CABLE RC	BD	STRIP	SEE CABLE RC
SHLD7	WHT GXL	16	4	AM	STRIP	SEE CABLE PC1B	AM	STRIP	SEE CABLE PC1B

6512101096

(SHEET 8 OF 9)

## Manitowoc Crane Group

WIRE NO	COLOR	SAE SIZE	LENGTH TOT IN	TP	B/M ITEM NO	REMARKS	TP	B/M ITEM NO	REMARKS
51S	WHT GXL	16	81	AK	49	---	AV	49	---
51T		16	85	AL	49	---	AV	49	---
51V		16	85	AL	49	---	AV	49	---
51W		18	78	AN	49	---	AV	49	---
51Y		14	70	AV	15	---	CP	15	---
51AA		16	89	BF	49	---	CG	28	CRIMP W/51AB
51AB		16	89	BF	49	---	CG	STRIP	CRIMP W/51AA
51AC		16	89	BG	49	---	CG	28	---
51AD		14	90	BH	15	---	CG	27	CRIMP W/51AE
51AE		14	90	BH	15	---	CG	STRIP	CRIMP W/51AD
51AG		18	67	BL	49	---	CP	49	---
51AH		18	74	BK	49	---	CP	49	---
51AK		18	72	BK	49	---	CP	49	---
51AL		18	92	BJ	49	---	CP	49	---
51AM		18	56	CB	51	---	CP	49	---
51AN		16	54	CC	49	---	CD	49	---
51AP		18	28	CF	49	---	CD	49	---
51AR		18	26	CF	49	---	CD	49	---
51AS		18	26	CF	49	---	CD	49	---
51AT		18	28	CF	49	---	CD	49	---
51AU		14	85	CD	15	---	CP	15	---
51AV		16	94	CH	46,47	---	SC8	STRIP	SEE DETAIL
51AW		16	94	CJ	13,14	---	SC8	STRIP	SEE DETAIL
51AX		16	97	CK	13,14	---	SC8	STRIP	SEE DETAIL
51AY		16	71	BR	49	---	AV	49	---
51BF		16	4	CD	49	---	SC8	STRIP	SEE DETAIL
51BG		16	5	CD	49	---	SC8	STRIP	SEE DETAIL
51BH		16	29	CM	48	---	SC8	STRIP	SEE DETAIL
51BJ		16	28	CN	48	---	SC8	STRIP	SEE DETAIL
51BK		16	97	CL	46,47	---	SC8	STRIP	SEE DETAIL
51BN		16	77	CP	49	---	BD	48	---
51BP		16	140	CD	49	---	BL	49	---
51BR		14	14	AV	15	---	AH	STRIP	CRIMP W/51BS
51BS		14	14	AV	15	---	AH	27	CRIMP W/51BR
51BT		14	13	CP	15	---	CG	STRIP	CRIMP W/51BV
51BV		14	13	CP	15	---	CG	27	CRIMP W/51BT
75		18	161	AP	49	---	BH	49	---
76		18	161	AP	49	---	BH	49	---
77		18	181	BH	49	---	CF	49	---
78		18	181	BH	49	---	CF	49	---
79A		16	101	AK	49	---	BH	49	---
80A		16	101	AK	49	---	BH	49	---
81A		18	159	AP	49	---	BH	49	---
82		18	159	AP	49	---	BH	49	---
83		18	179	BH	49	---	CF	49	---
84		18	179	BH	49	---	CF	49	---
89A		16	97	BH	49	---	CE	48	---
133A		16	153	BH	49	---	SA1	STRIP	SEE DETAIL
133B		16	22	AR	49	---	SA1	STRIP	SEE DETAIL
133C	WHT GXL	16	77	AB	13,14	---	SA1	STRIP	SEE DETAIL

# Manitowoc Crane Group

WIRE NO	COLOR	SAE SIZE	LENGTH TOT IN	TP	B/M ITEM NO	REMARKS	TP	B/M ITEM NO	REMARKS
2A	WHT GXL	18	25	BH	45	---	SB2	STRIP	SEE DETAIL
2B	WHT GXL	18	82	SB2	STRIP	SEE DETAIL	AJ	49	---
2C	WHT GXL	18	72	SB2	STRIP	SEE DETAIL	CE	48	---
5	YEL SXL	6	56	AM	20	---	BC	25	---
6A	YEL SXL	6	56	AM	20	---	BC	25	---
8A	WHT GXL	14	164	BH	15	---	SC5	STRIP	SEE DETAIL
8B		16	87	CJ	13,14	---	SC5	STRIP	SEE DETAIL
8C		16	22	CM	48	---	SC5	STRIP	SEE DETAIL
8D		16	22	CN	48	---	SC5	STRIP	SEE DETAIL
8E		16	91	CK	13,14	---	SC5	STRIP	SEE DETAIL
8F		14	164	BH	15	---	SC5	STRIP	SEE DETAIL
13A		14	26	BH	15	---	SB2	STRIP	SEE DETAIL
13B		16	123	AS	48	---	SB2	STRIP	SEE DETAIL
13C		16	123	AR	49	---	SB2	STRIP	SEE DETAIL
13D		14	139	SC6	STRIP	SEE DETAIL	SB2	STRIP	SEE DETAIL
13E		16	86	SC6	STRIP	SEE DETAIL	CH	46,47	---
13F		16	21	SC6	STRIP	SEE DETAIL	CM	48	---
13G		16	21	SC6	STRIP	SEE DETAIL	CN	48	---
13H		16	90	SC6	STRIP	SEE DETAIL	CL	46,47	---
13J		16	10	AT	15	---	SB2	STRIP	SEE DETAIL
13K		16	61	BR	15	---	SB2	STRIP	SEE DETAIL
14A		14	137	BH	15	---	SA2	STRIP	SEE DETAIL
14B		16	93	AA	46,47	---	SA2	STRIP	SEE DETAIL
14C		16	8	AR	49	---	SA2	STRIP	SEE DETAIL
14E		16	275	CM	48	---	SA2	STRIP	SEE DETAIL
15A		14	136	BH	15	---	SA2	STRIP	SEE DETAIL
15B		16	90	AD	46,47	---	SA2	STRIP	SEE DETAIL
15C		16	9	AS	48	---	SA2	STRIP	SEE DETAIL
15E		16	274	CN	48	---	SA2	STRIP	SEE DETAIL
16A		16	251	BH	15	---	CH	46,47	---
17		16	255	BH	15	---	CL	46,47	---
25		18	97	BH	45	---	CE	48	---
32		18	98	AN	50	---	BH	45	---
41A		16	167	BH	15	---	SC9	STRIP	SEE DETAIL
41B		16	19	CM	48	---	SC9	STRIP	SEE DETAIL
41C		16	19	CN	48	---	SC9	STRIP	SEE DETAIL
51A		16	91	AA	46,47	---	AE	49	---
51B		16	91	AB	13,14	---	AE	49	---
51C		16	87	AC	13,14	---	AE	49	---
51D		16	87	AD	46,47	---	AE	49	---
51E		16	14	AE	49	---	AS	48	---
51F		16	14	AE	49	---	AS	49	---
51G		16	12	AT	49	---	AV	49	---
51H		18	22	AE	49	---	AP	49	---
51J		18	20	AE	49	---	AP	49	---
51K		18	20	AE	49	---	AP	49	---
51L		18	22	AE	49	---	AP	49	---
51M		14	125	AV	15	---	AE	15	---
51N		18	85	AJ	49	---	AV	49	---
51P	WHT GXL	16	81	AK	49	---	AV	49	---

6512101096

(SHEET 6 OF 9)

# Manitowoc Crane Group

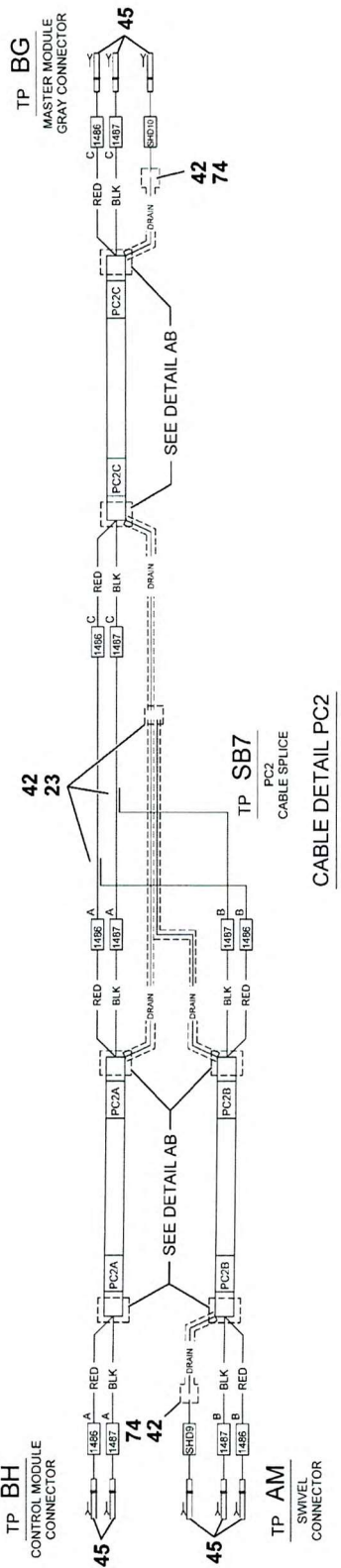
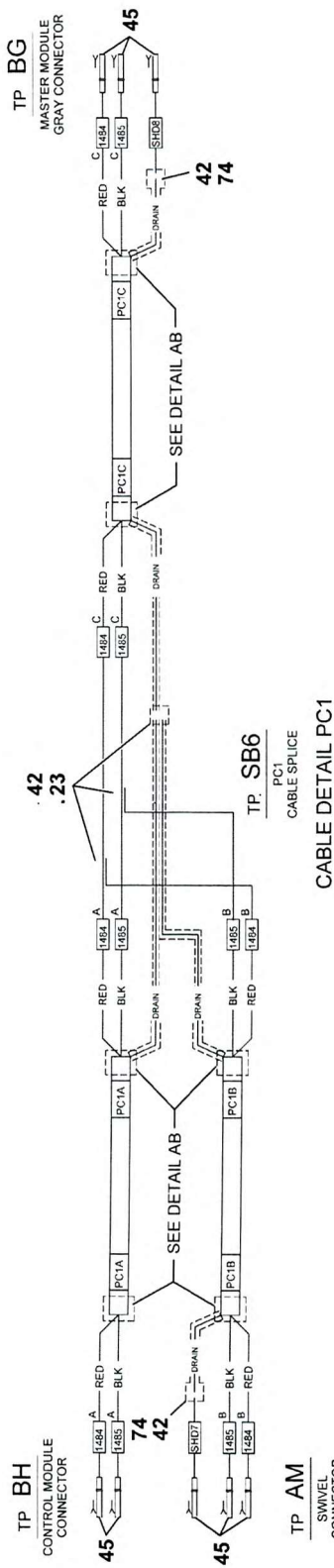
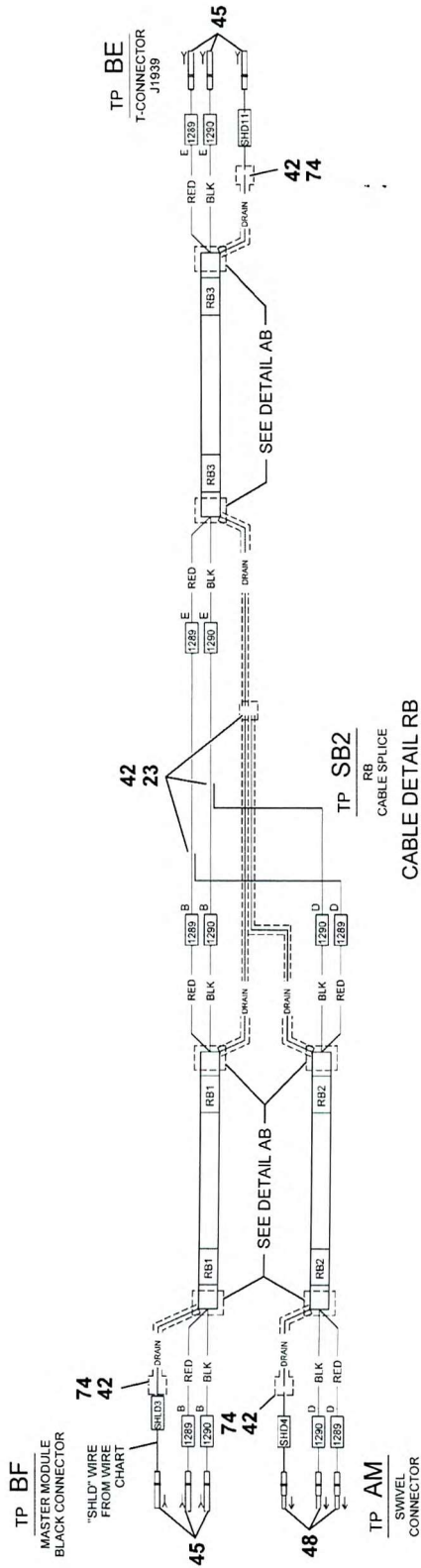

# Manitowoc Crane Group

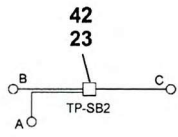

DETAIL 2

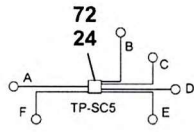

DETAIL 8

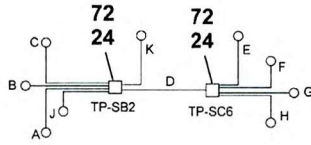

DETAIL 13

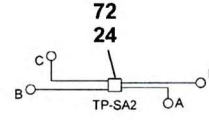

DETAIL 14

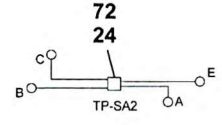

DETAIL 15

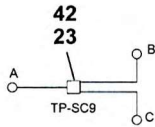

DETAIL 41

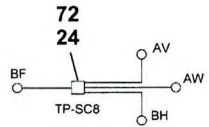

DETAIL 51

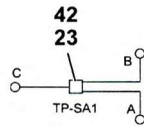
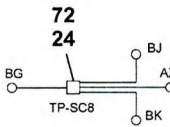

DETAIL 133

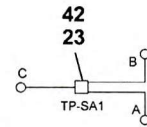

DETAIL 134

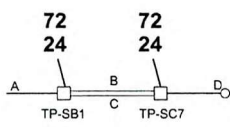

DETAIL 344

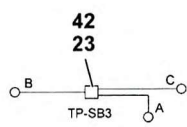

DETAIL 440

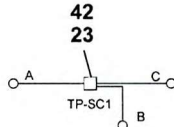

DETAIL 609

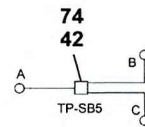

DETAIL 713

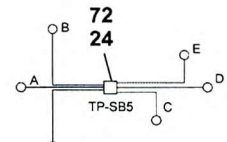

DETAIL 1410

TP BE  
T-CONNECTOR  
J1939

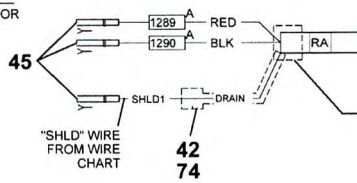

VIEW RA  
CABLE DETAIL RA  
J1939 DATALINK

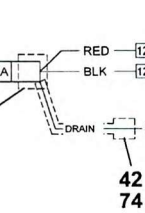

TP CE  
ENGINE  
CONNECTOR

TP BE  
T-CONNECTOR  
J1939

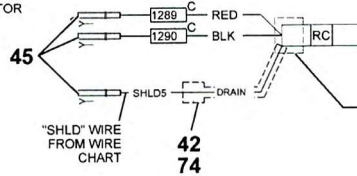

VIEW RC  
CABLE DETAIL RC  
J1939 DATALINK

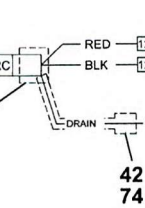

TP BD  
CARRIER CONTROL  
MODULE DIAGNOSTIC  
CONNECTOR

TP BF  
MASTER MODULE  
J1939 CONNECTION  
BLACK CONNECTOR

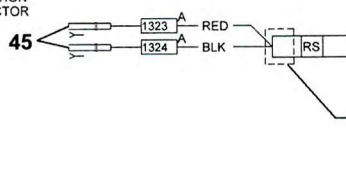

VIEW RS  
RS232

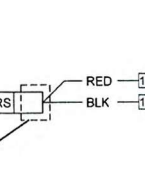

TP BD  
CARRIER CONTROL  
MODULE DIAGNOSTIC  
CONNECTOR

6512101096

(SHEET 4 OF 9)

Page 597

# Manitowoc Crane Group

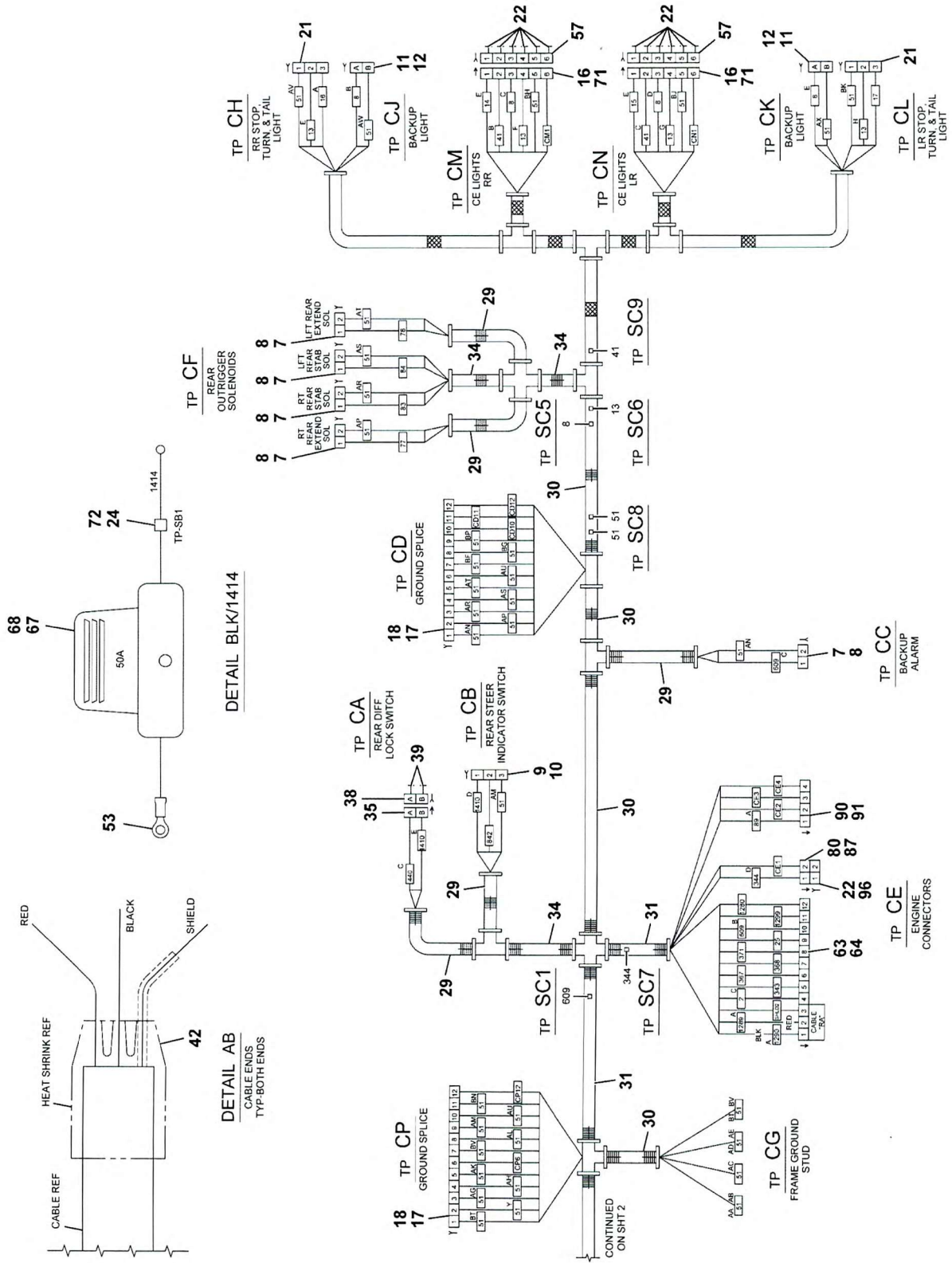

6512101096

(SHEET 3 OF 9)

# Manitowoc Crane Group

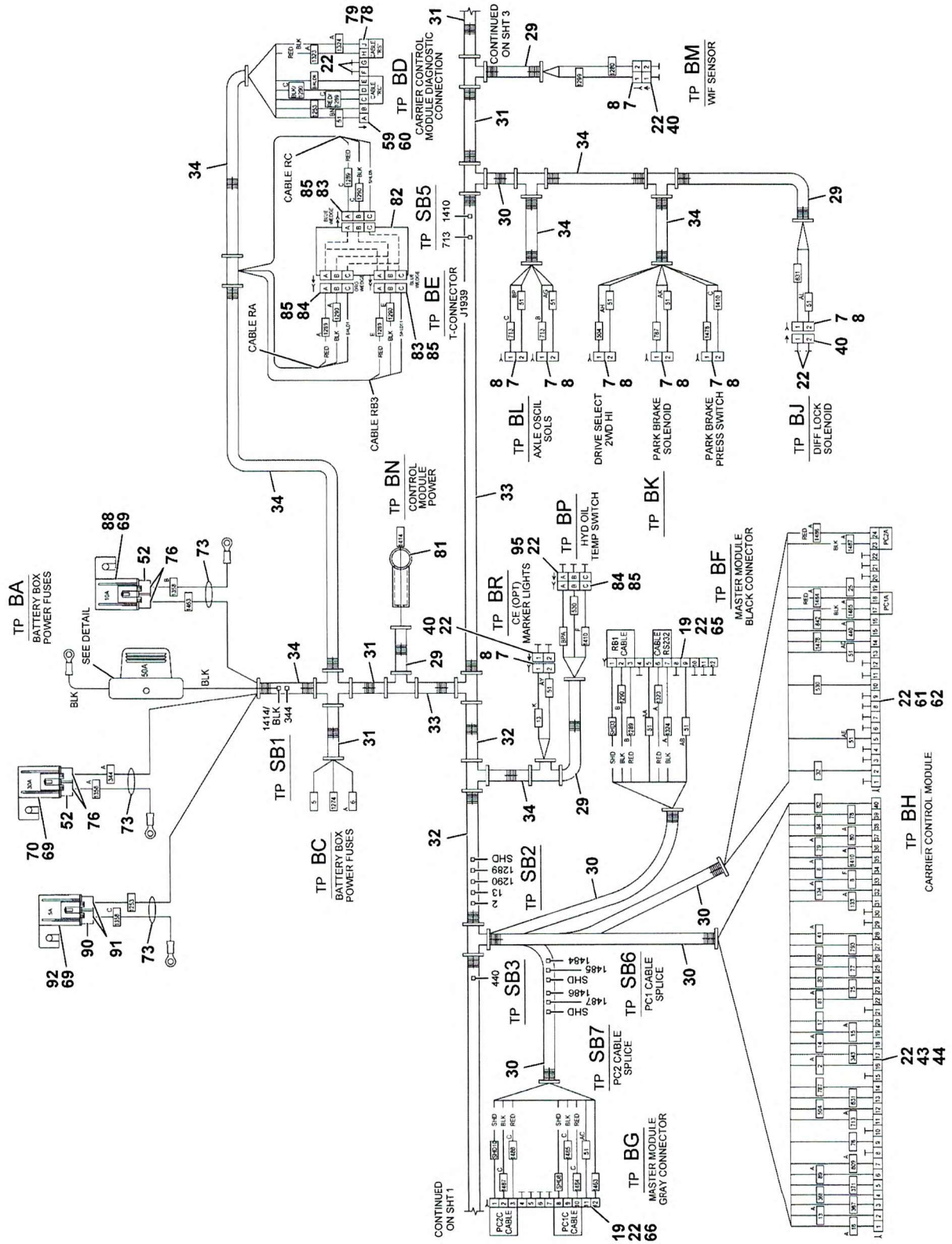

6512101096

(SHEET 2 OF 9)



# Manitowoc Crane Group

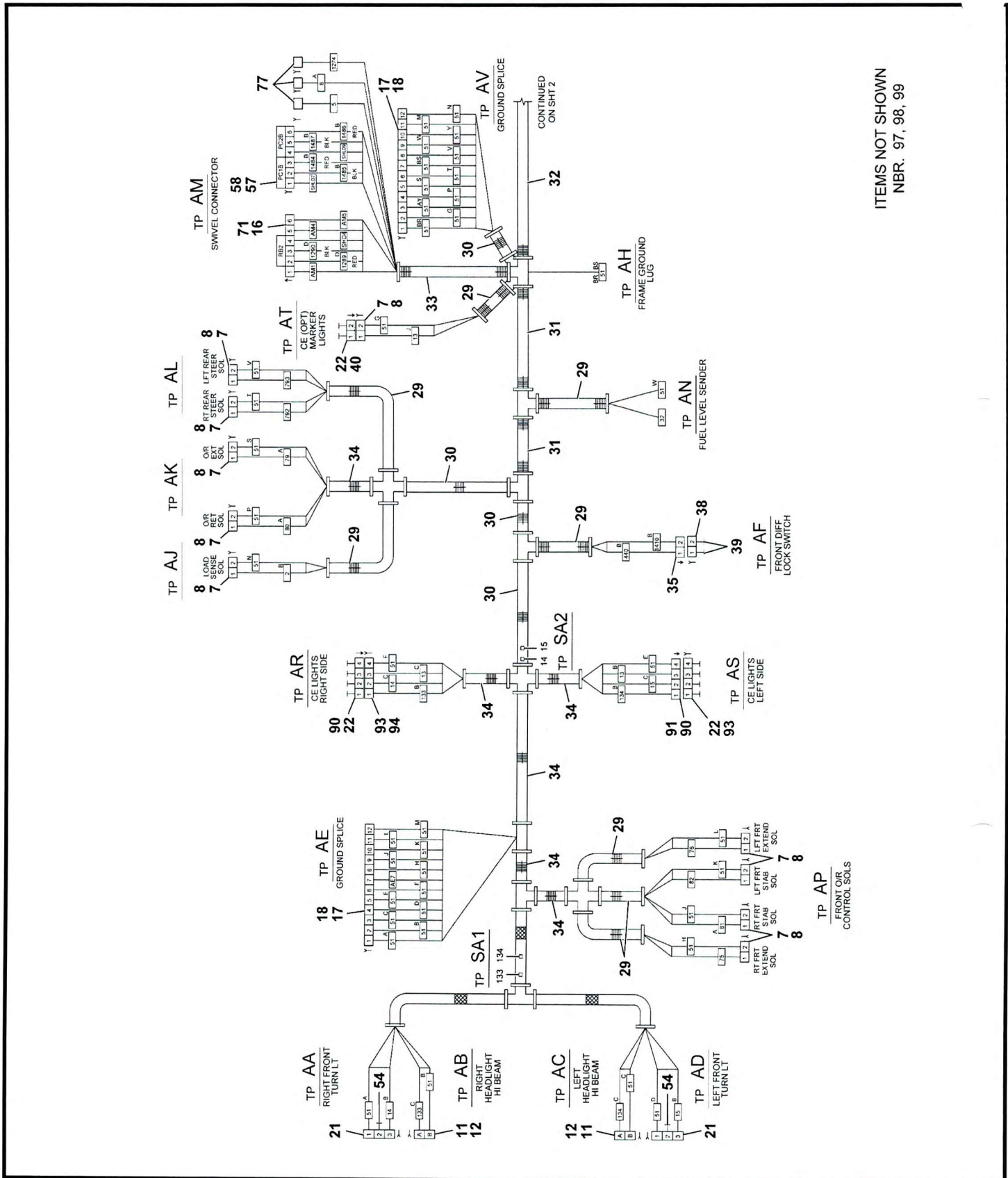

ITEMS NOT SHOWN  
NBR. 97, 98, 99